



Options

Duct Collar Adapter

Duct Collar Adapters	
Model No.	Description
19950	10" Duct Collar Adapter with galvanized finish
19951	12" Duct Collar Adapter with galvanized finish

* No Prefilter is used
 * Two required for 2' x 6' models

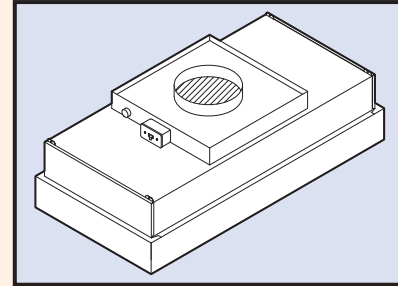

Top Load Duct Collar Adapters (Allows the Prefilter to be changed from the top)	
Model No.	Description
19955	Top Load Adapter w/10" Duct Collar Adapter with galvanized finish
19956	Top Load Adapter w/12" Duct Collar Adapter with galvanized finish

* Two required for 2' x 6' models
 * Add 1-1/2" to total height of unit

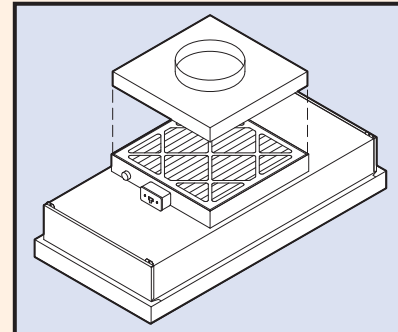

Side Load Prefilter w/Duct Collar (Allows the Prefilter to be changed from the side when space is limited)	
Model No.	Description
19952	Side Load Prefilter Frame w/10" Duct Collar Adapter with galvanized finish
19953	Side Load Prefilter Frame w/12" Duct Collar Adapter with galvanized finish

* Two required for 2' x 6' models
 * Add 1-1/2" to total height of unit

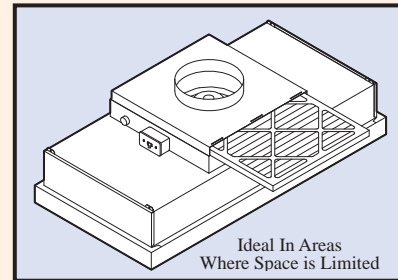

Air Conditioning Mixing Box (Allows Conditioned Air Connection to Unit)	
Model No.	Description
19958	With 10" Duct Collar
19959	With 12" Duct Collar

* For Open Plenum Systems
 * Galvanized finish and White Powdercoat finish available

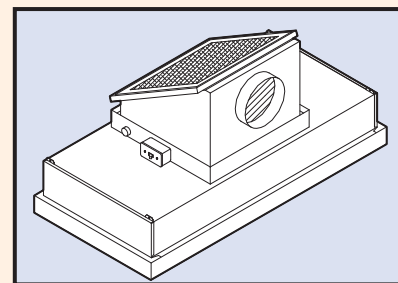

Mixing Box (Allows Conditioned Air Connection to Unit)	
Model No.	Description
19947	With 10" Duct Collar
19948	With 12" Duct Collar

* Galvanized finish and White Powdercoat finish available

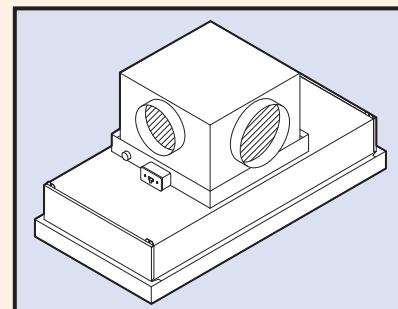

NOTE: Duct collar adapters #19950 & #19951 may be used without negating the UL listing. All other duct collars and mixing boxes negates UL listing.